

# FORD RANGER MOBILE CLINIC

## VEHICLE SUMMARY

A heavy-duty 1-ton pickup developed in conjunction with international health organizations to provide mobile assistance during disease outbreaks.



Rail mount fridge



Dual and deep cycle battery system



Rail mount fridge

\* Some features shown are optional



**FORD GLOBAL FLEET SALES**

[inquiries@globalfleetsales.net](mailto:inquiries@globalfleetsales.net)

[ford.globalfleetsales.net](http://ford.globalfleetsales.net)

# FORD RANGER MOBILE CLINIC

## Vehicle Details

Manufacturer	Ford
Model	Ranger Double Cab
Engine	2.5L Duratec Petrol DOHC with iVVT
Power (kW)	122 @ 6000 rpm
Torque (Nm)	226 @ 4500 rpm
Drivetrain	4X4
Transmission	5-speed manual
Fuel tank capacity	80L
Wheels	17" alloy
Tires	Semi-rough pattern

## Dimensions of Modified Vehicle (mm)

Length	5359
Width	1850
Height	1815
Angle of approach (°)	28
Angle of departure (°)	26
Wheelbase	3220
Track width	1560
Ground clearance	232
Turning circle (m)	12

## Weight Table (kg)

Base vehicle unladen kerb weight	1913
Modified vehicle unladen kerb weight	2141
1) Front axle	1211
2) Rear axle	930
Payload capacity	1059
Gross modified vehicle weight	3200

### Notes:

The company reserves the right to change the vehicle specifications and features described in this publication at any time. Vehicle specifications and features may vary in different markets. Images are for illustrative purposes only and may appear different from the actual vehicle.

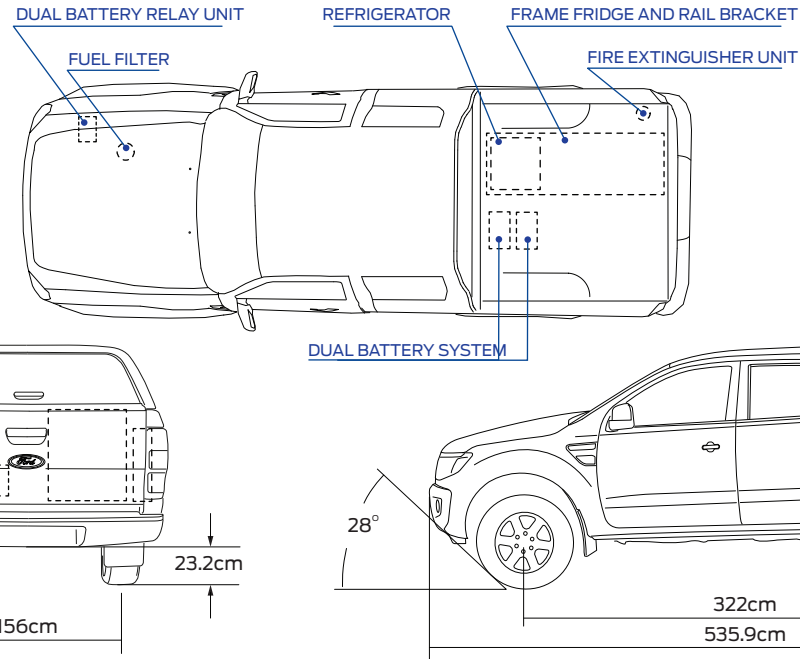

## Standard Features

ABS double canopy  
Portable fridge freezer  
Dual and deep cycle battery

Bedliner  
Dome light kit  
Fire extinguisher 1 kg [X2]

## Optional Features

Brake system upgrade  
Enhanced handling suspension package  
Enhanced fuel filtration system  
Enhanced fuel filtration system with coolant block heater  
Long range fuel tank for maximum range (115L)

Window tinting  
First aid emergency safety kit  
Accessory pack  
Recovery pack  
1 Year replacement pack



FORD GLOBAL FLEET SALES

✉ inquiries@globalfleetsales.net

🌐 ford.globalfleetsales.net